

Input of Photo SBU on the Topic of Application for RoHS Renewal

The option of using glass types containing lead or cadmium is absolutely vital for the Photo SBU, when specific optical characteristics and/or maximum demands on quality have to be met. It is also indispensable for the fulfillment of the services which have been pledged to customers, such as the repair of damaged lenses which is expected by our customers for decades to come.

In the field of aerial photography (cine applications), where the Photo SBU is one of the leading manufacturers of high-quality lenses, not only the characteristics (such as image quality or color location – CCI value) of an individual lens of a given focal length must be taken into consideration. Unlike still photography, the lens too must be regarded as part of a batch of lenses of different focal lengths (prime and zoom lenses). In consequence, the distribution in both the image quality and the color location of the lenses in a batch must be reduced to a level where it is unnoticeable. The loss of one or two lenses may therefore – depending on the quality of the focal lengths in a batch – jeopardize the usability of an entire batch. Of course, this also relates to cases of irreparable lenses in sold off batches.

Glass types such as KZFS are vital for optical design in order to obtain maximum image quality, i.e. high contrast and optimal definition. This is because KZFS types are indispensable for color correction (longitudinal and lateral chromatic aberrations) in the most demanding applications.

Dispensing with these glass types inevitably leads to increased input in the optical design (amount of lens elements). Thus, due to the higher level of stray light and reflection, the image quality is significantly reduced. In addition, dispensing with leaded SF glass types leads to a significant loss of transmission in the blue wavelength range, resulting in a significant displacement of the CCI value.

In the area of photogrammetric systems, it is sometimes necessary to use color filters to split the 400-950 nm wavelength range into different color channels (RGB + close range IR), which are then recorded separately. This requires high-quality color filters which feature both high edge steepness and minimal dependence on the angle of incidence of the incident light. Thus, interference filters should be regarded as not usable or only producible through substantial input (amount of layers).

The color channels must be designed without a noticeable overlap, and at the same time, the wavelength spectrum must be presented with no large gaps. To achieve this, filters with a high degree of edge steepness are indispensable.

Dispensing with glass types containing lead or cadmium may not make solutions for these tasks outright impossible, but would certainly lead to increased input (e.g. amount of optical elements). However, since the physical construction conditions must sometimes be complied with as hard requirements (weight, volume, diameter, etc.), a solution may also fail due to the additional inputs

required. Examples include high-quality scanner lenses for the digitalization of film material which must be fitted into the available space of the system, or systems for military applications.

This special treatment of glass types containing lead or cadmium is based on their unique characteristics, e.g. transmission in the 380-450 nm range, special features of the dispersion process (abnormal partial dispersion) or special features of the general transmission process (optical filters).

Before proceeding to provide some concrete examples and describe the problems incurred through dispensing with lead and/or cadmium, we wish to present some key factors for describing optical glass.

In lens design, types of optical glass are classified in accordance with their special characteristics in relation to light refraction and color dispersion. Light refraction is evaluated in accordance with the refractive index n against air, usually for the yellow helium line d . The refractive indices of types of optical glass are in the range from 1.43 to 2. Heavy atoms such as lead, thorite or barium strongly increase the refractive index, while light atoms decrease it. The color dispersion is oriented towards the changeability of the refractive index with the light wavelength. As the wavelength decreases, the refractive index increases. The difference $n(F) - n(C)$ of the refractive indices for the F and C hydrogen lines is called medium color dispersion. However, the Abbe number $\nu = (n(d) - 1) / (n(F) - n(C))$, the reciprocal relative color dispersion, is significant for lens design because this factor arises in the achromatism condition.

Since the refractive index varies with the wavelength of the light, the image locations for various wavelengths generally do not fall one on top of the other. Rather, they are far away from each other.

Problem der Farbortslage

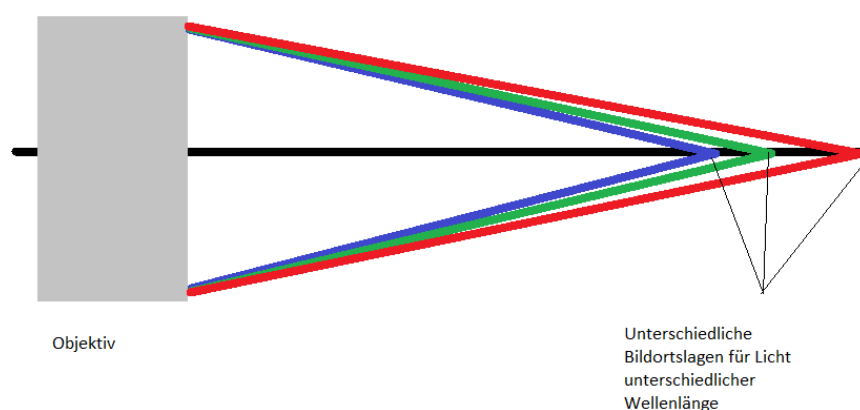

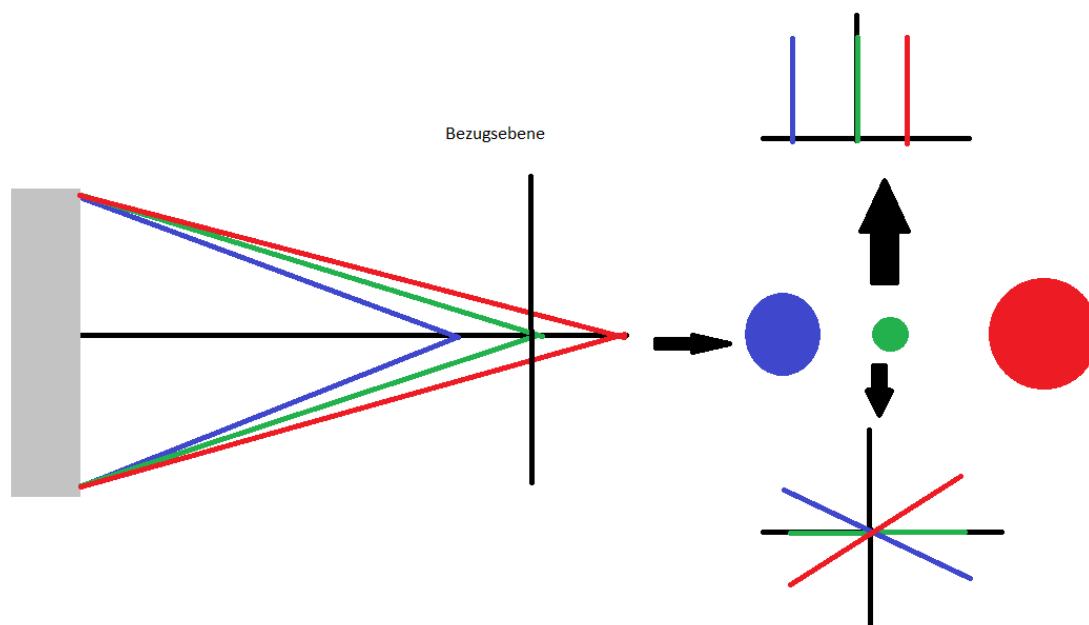

Due to the dispersion of types of optical glass, the image points for various wavelengths do not fall one on top of the other. As a result, image slices of various diameters for the different wavelengths are produced, through which color fringes develop. Common display formats include: (a) the representation of the axially measured difference to a reference wavelength as a function of the aperture (above right), and (b) the representation of the radius of the image slice above the aperture (below right).

The task of lens design is to arrange the image locations for the entire spectral range close together enough. Therefore, the achromatism condition must be fulfilled for both the F and C wavelengths.

$$\sum_{i=1}^{i=n} (g(i) * F(i) / (v(i) * F)) = 0$$

in which the sum is the total of the single lens elements. $g(i)$ represents a factor which is dependent on the wavelength, which reflects the constructive singularity of the system, $F(i)$ the refractive power of the lens element i , $v(i)$ the Abbe number of the glass in the lens element i , and F the refractive power of the entire system. Fulfilling this condition guarantees that the image locations for the F and C wavelengths fall one on top of the other. Nevertheless, the image locations of the remaining wavelengths are far away from here – which is termed the secondary spectrum.

The secondary spectrum appears because the path of the color dispersion is uneven in the spectral range, and different for various glass types. The path of color dispersion is expressed through

absolute partial dispersions $n(h) - n(g)$, $n(g) - n(F)$, $n(F) - n(e)$, $n(e) - n(C)$, $n(C) - n(A')$, and/or through relative partial dispersion in relation to $n(F) - n(C)$.

Apochromatic theory places the removal of the secondary spectrum – absolutely essential for the highest image quality of a lens – in the foreground of the considerations. On this basis, it follows that the relative partial dispersion of the materials takes on a key significance.

On a simple lens made up of two lens elements, this can be simply recognized (the color locations of the F,g and C wavelengths should be aligned).

For the refractive power F of the system, the following applies: $F = F_1 + g(2) \cdot F_2$.

For color correction, two equations must now be satisfied:

- 1) $F_1/(v_1 \cdot F) + g(2)^2 \cdot F_2/(v_2 \cdot F) = 0$
- 2) $F_1/(v_{11} \cdot F) + g(2)^2 \cdot F_2/(v_{22} \cdot F) = 0$

F_1 , F_2 designate the refractive powers of the lens elements; $g(2)$ represent the system structure components (it is $g(1)=1$) and $v_1 = (n_1(d)-1)/(n_1(F)-n_1(c))$, $v_{11} = (n_1(d)-1)/(n_1(g)-n_1(F))$, $v_2 = (n_2(d)-1)/(n_2(F)-n_2(c))$, $v_{22} = (n_2(d)-1)/(n_2(g)-n_2(F))$. If the relative partial dispersion

$P_{gF} = (n(g)-n(F))/(n(F)-n(c))$ is now introduced,

equation 2 can also be written as:

$$2a) P_{1gF} \cdot F_1/(v_1 \cdot F) + g(2)^2 \cdot F_2 \cdot P_{2gF}/(v_2 \cdot F) = 0.$$

As equations 1 and 2 must be satisfied at the same time, it follows that the relative partial dispersions of the types of glass must be identical. This reveals the central significance of relative partial dispersion for color correction.

The values of the absolute partial dispersions, and therefore of course those of the relative partial dispersions also, are generally different for the individual types of glass, and depend on the chemical composition.

Traditionally, glass types are divided into two groups: crowns and flints. The types of glass in the crown group have an Abbe number over 55, while those in the flint group have an Abbe number which is below 50. There are some intermediate types of glass between both of these large groups. While the Abbe number of the types of glass in the crown group is higher than that of those in the flint group, with the P_{gF} values, the behavior is the opposite: the types of glass of the crown group have a lower P_{gF} value than the types of glass of the flint group. As calculated above, two groups of glass types are particularly interesting for color correction – one being the long crown and the other the short flint.

Although short flints have an Abbe number below 50, they have a significantly lower P_{gF} value than comparable glasses with the same Abbe number. The long crowns, on the other hand, have an Abbe number over 55. However, they have a significantly lower P_{gF} value than comparable glasses with the same Abbe number.

Now, even in monochromatic terms, the idea of a point-shaped representation is impossible. There are larger or smaller deviations from the point-shapedness of the image points, for example spherical

aberrations, astigmatism, shell errors or distortion, and all these defects depend on the wavelength of the light.

In total, the interrelations caused by deviations from point-shapedness are too complex to calculate in a purely analytical manner based on the construction parameters (radii, thicknesses, refractive indices, etc.). To do this, computer programs are used, which determine these deviations using the "ray tracing" method.

Aberration diagrams produce an initial rough overview of the image quality of a lens; and these are mainly used in two forms.

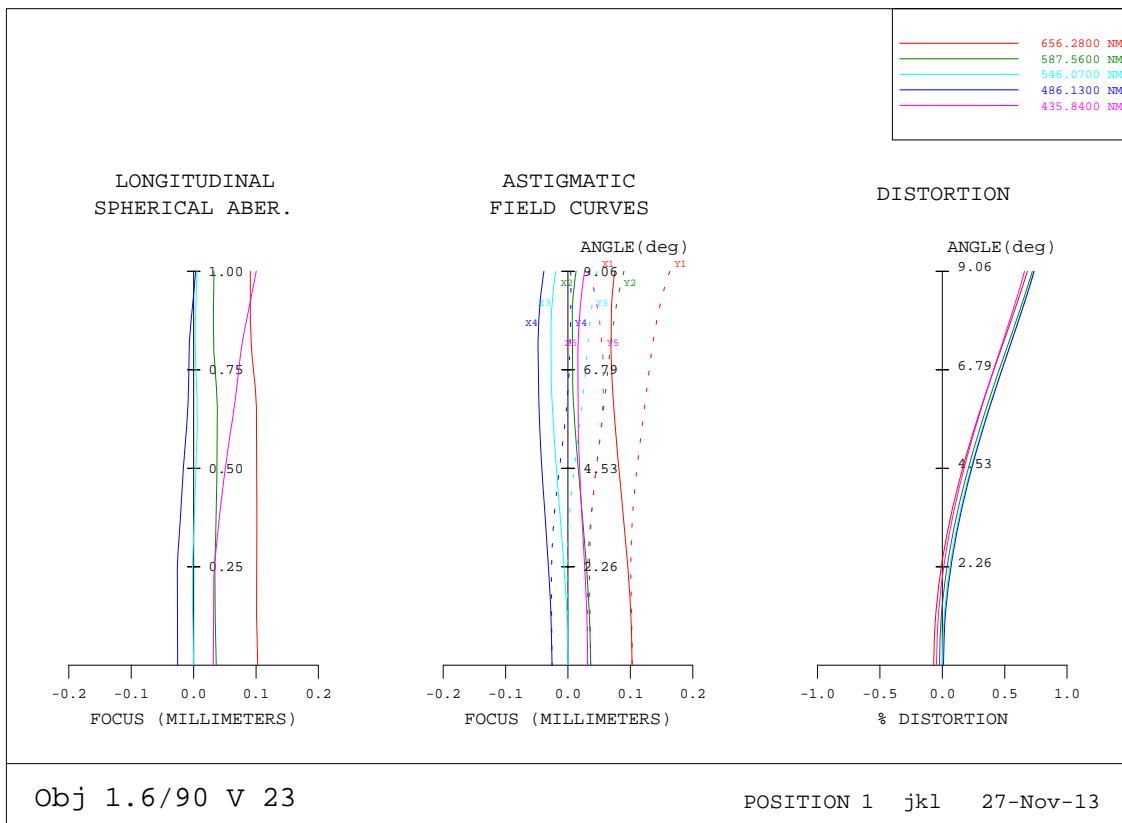

In this first format, the spherical aberration, shell errors and distortion are presented for different wavelengths.

The above-mentioned chromatic variation in the image location is obvious through the different position on the axis in the imaging of the spherical aberration as well as in the representation of the shell errors. Furthermore, these representations can be extracted in the case of a spherical aberration, so that this chromatic variation is not constant across the aperture, in the case of the image shell, that this is not constant across the image field and even the distortion is subject to a chromatic variation.

In the case of perfect imaging, all these curves must be identical to a single straight line. The further away from each other these curves fall is a reference to the loss of the image quality of the lens.

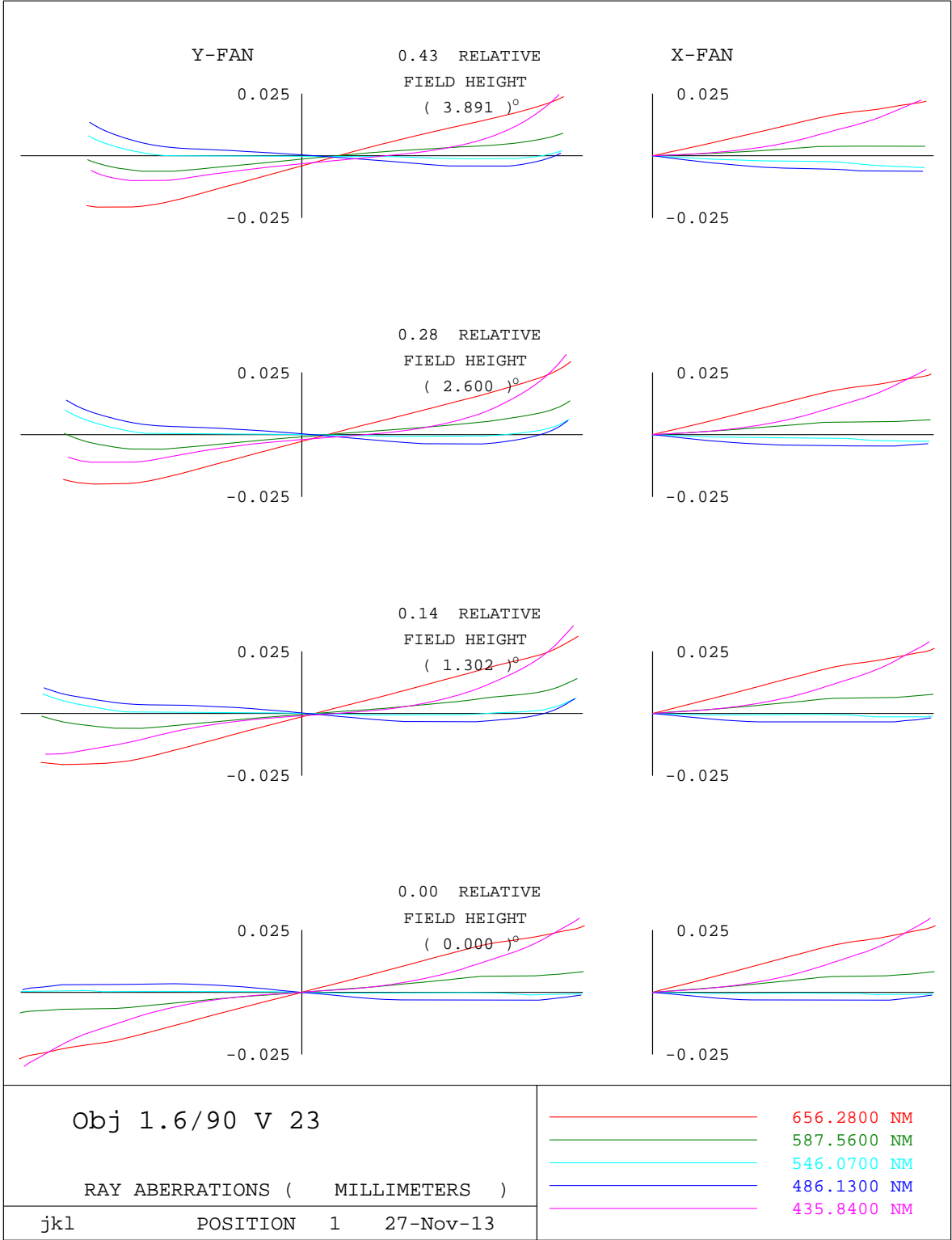

While in the previous diagram, the image locations measured along an axis are in the foreground, in the lateral aberration diagram, the relationships in the image point are in the foreground. They show how the diameter of the image point develops depending on the aperture in two sections which are facing each other vertically (right and left column). The chromatic variation of the image location is the cause for the different gradient against the axis, which leads to different diameters of the image point for different wavelengths, and thus to color edges and color fringes in the image. A very disruptive effect, which can be detected very easily – even by untrained photographers – using today's digital technology, and evaluated through a simple count of the image pixels.

Even if the contents of the diagrams are presented in a very simplified manner, one senses that no objective quality criterion for evaluating the imaging performance of a lens can be based on this alone.

This was why the modulation transfer function was developed.

In this function, the lens is regarded as a "black box," whose constructional characteristics are unknown. On the image level, the lens shows an illuminated object whose brightness distribution is known (in our company an illuminated slot). The brightness profile of the image is scanned by means of a detector.

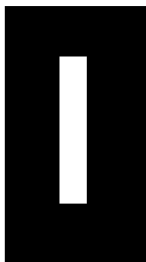

Beleuchteter Spalt, dessen Fourier-Spektrum bezüglich der Helligkeitsverteilung bekannt ist.



Objektiv, als "Black Box", bildet den Spalt ab.



Bild des Spaltes, dessen Fourier-Spektrum bezüglich der Helligkeitsverteilung analysiert wird.

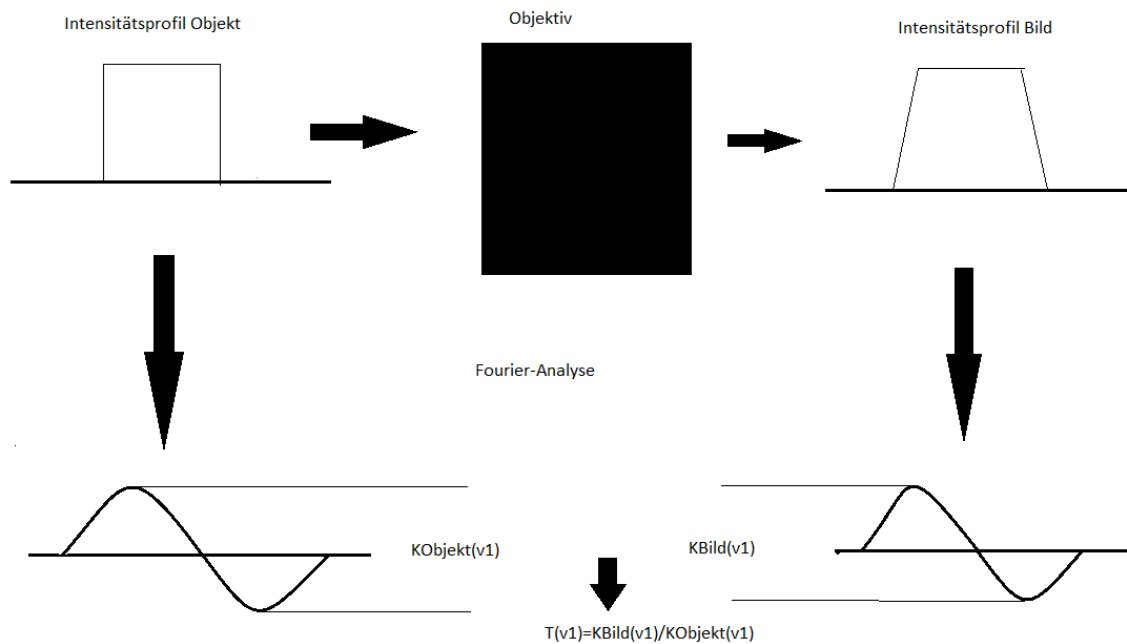

Through fourier analyses, these brightness distributions are then broken down into basic functions (sinus profile) and in each case, the contrasts of the object and image columns determined. If $K_{\text{object}}(v)$ represents the contrast of the object at the v frequency, and $K_{\text{image}}(v)$ represents the contrast of the image at the v frequency, the influence of the lens in the imaging of the split in the image may be described through the following quotients: $T(v) = K_{\text{image}}(v)/K_{\text{object}}(v)$. The object contrast is usually normalized to the value 1, so that the $T(v)$ factor can assume values of between 0 (no transfer) and 1 (flawless transfer). Naming as K_{image} a column vector whose elements represent the contrasts to the v frequencies, and analogous to K_{object} a column vector whose elements represent the object's contrasts to the v frequencies, the imaging property of the lens may be completely represented by a matrix equation of the type

$$\underline{K}_{\text{image}} = \underline{T} * \underline{K}_{\text{object}}$$

with T denoting a quadratic matrix whose elements are only different from 0 on the diagonals, and represent the $T(v)$ values on the diagonals.

The T matrix is called the contrast rendition matrix, or the contrast rendition function. The diagonal elements $T(v)$ of this matrix are called the contrast rendition factor to the v frequency.

Obviously, the higher the $T(v)$ values are, the more perfect the imaging will be (but the $T(v)$ transfer factors are limited to < 1 through diffraction effects).

A clear representation of the imaging performance of a lens is obtained by applying the contrast rendition factor for three particular spatial frequencies representing special imaging properties above the image height.

(The frequencies 10LP/mm 20LP/mm and 40LP/mm are usually chosen for this.

The 10LP/mm frequency represents how rough object structures are imaged, which is also often referred to as contrast sharpness or contrast.

The 20LP/mm frequency represents how sharp edges are imaged in the brightness profile.

The 40LP/mm frequency represents how well small object structures are imaged, which is also often referred to as image sharpness or simply sharpness.).

See the following picture:

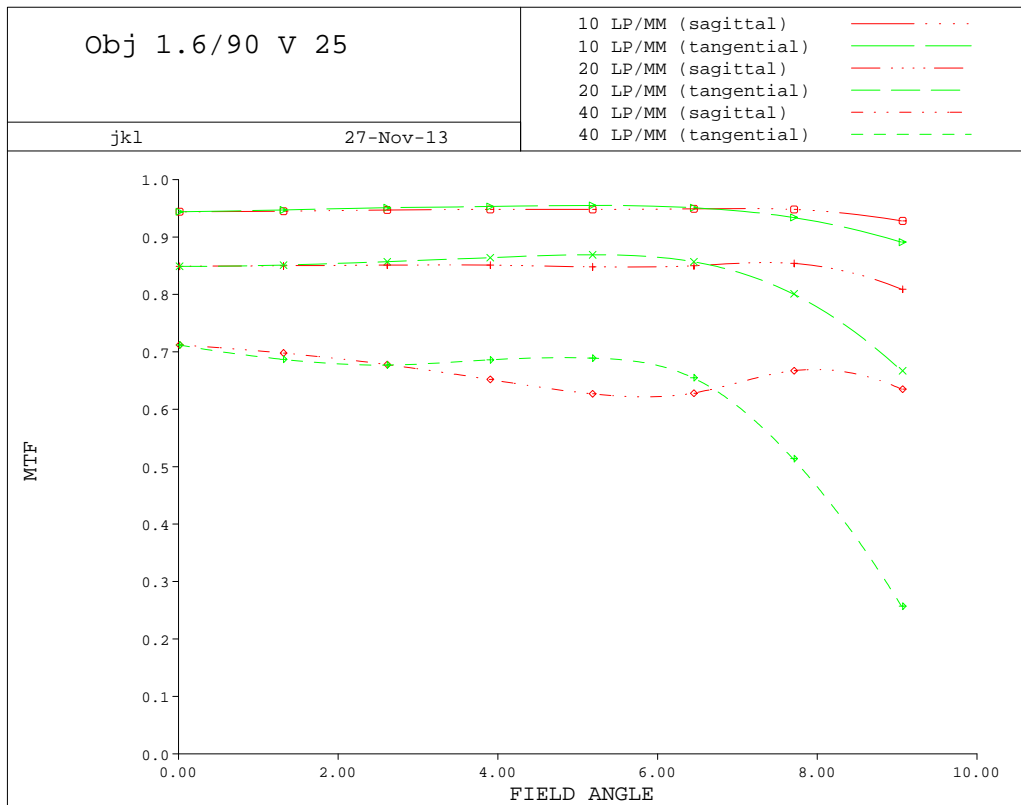

However, the MTF inspection represents a very comprehensive evaluation and does not allow for the possible causes of the quality-reducing effects to be recognized. For this, we use a "test subject" (see picture below) which is captured using the lens to be tested, and the image is subjected to a visual inspection.



Fig. 1

Some of the above-mentioned aspects are presented with specific examples below.

Technical Reason 1 – Loss of Image Quality

Types of optical glass are characterized by their position in the nd-vd diagram based on the refractive index (nd) and Abbe number (vd) parameters. However, this does not adequately describe the optical characteristics. Partial dispersion and relative partial dispersion are also essential characteristics. These factors may differ even for types of glass which have identical refractive indices and Abbe numbers. Examples can be found among the KZFS glass types and their lead-free replacement glass types, such as the Ohara SNBH glass types. These differences have considerable consequences on the optical design in relation to the image quality.

See below the image quality in the form of MTF for 10, 20 and 40 LP/MM for a lens with leaded KZFS glass type and a version converted to lead-free SNBH type for full aperture 1.4 and stopping down to aperture 4. Thus, even with stopping down to aperture 4, this imaging performance cannot be re-attained.

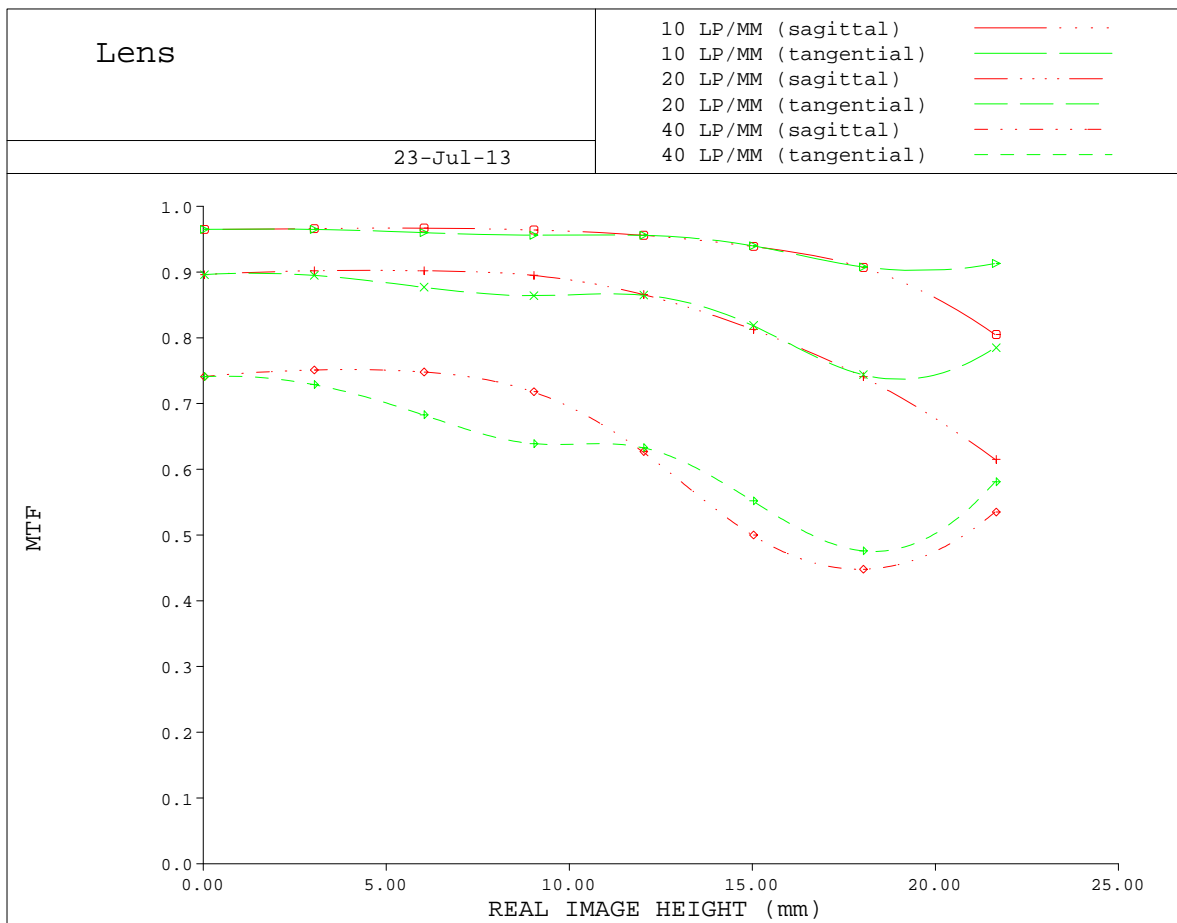

Drastischer Verlust an Abbildungsgüte

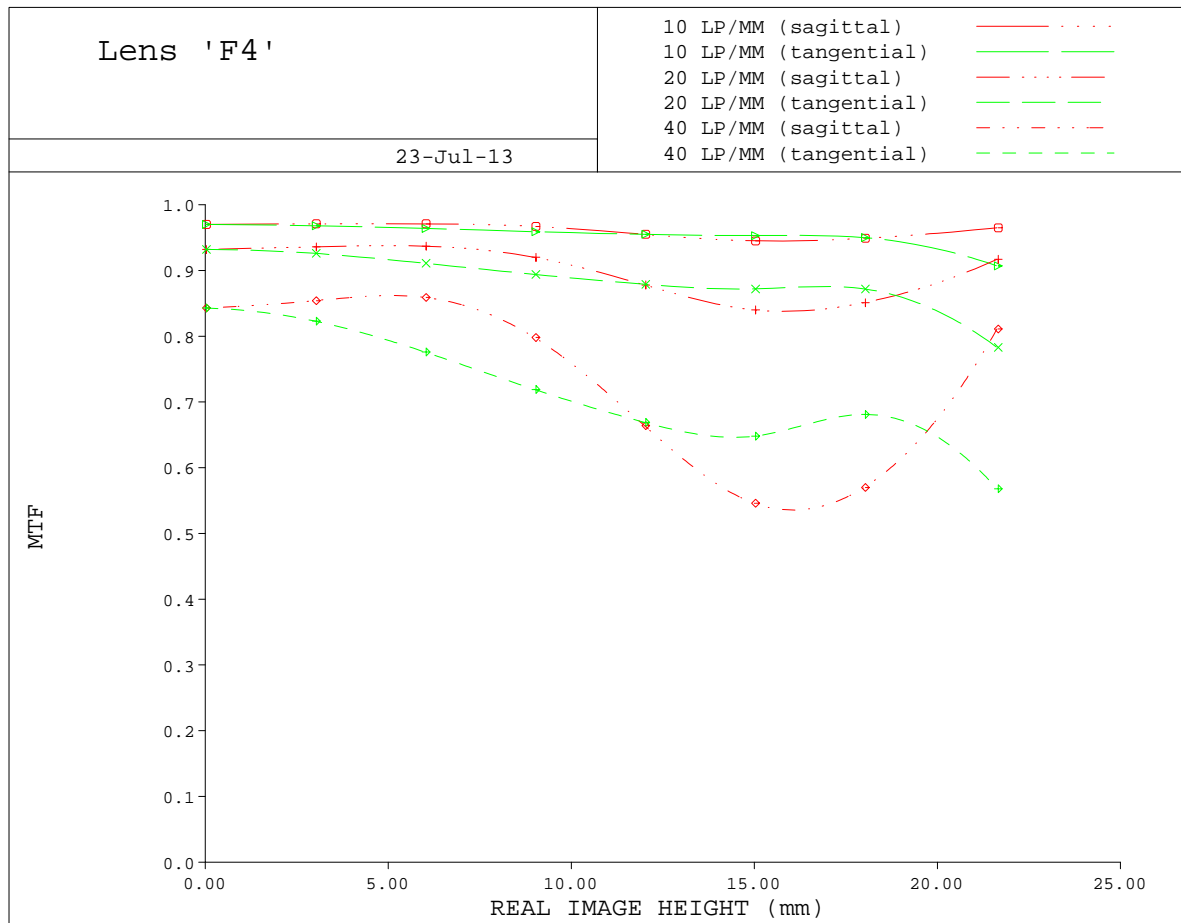
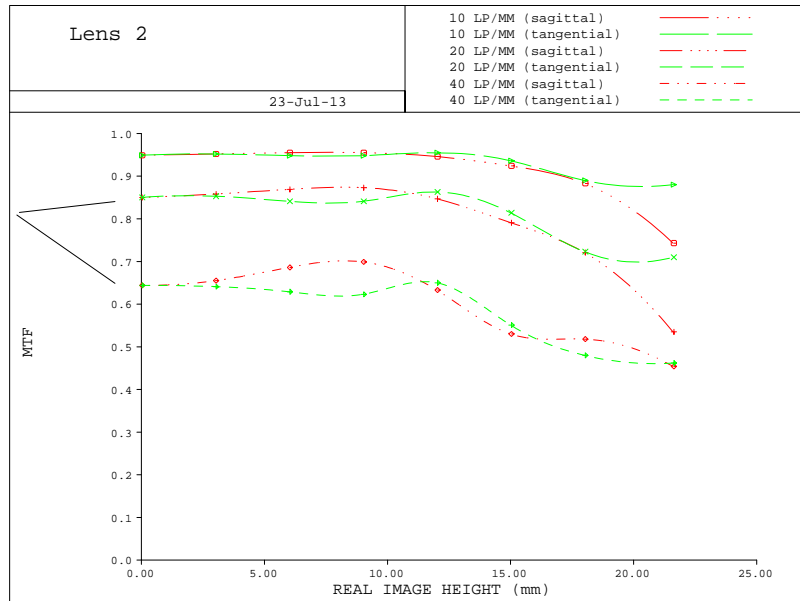

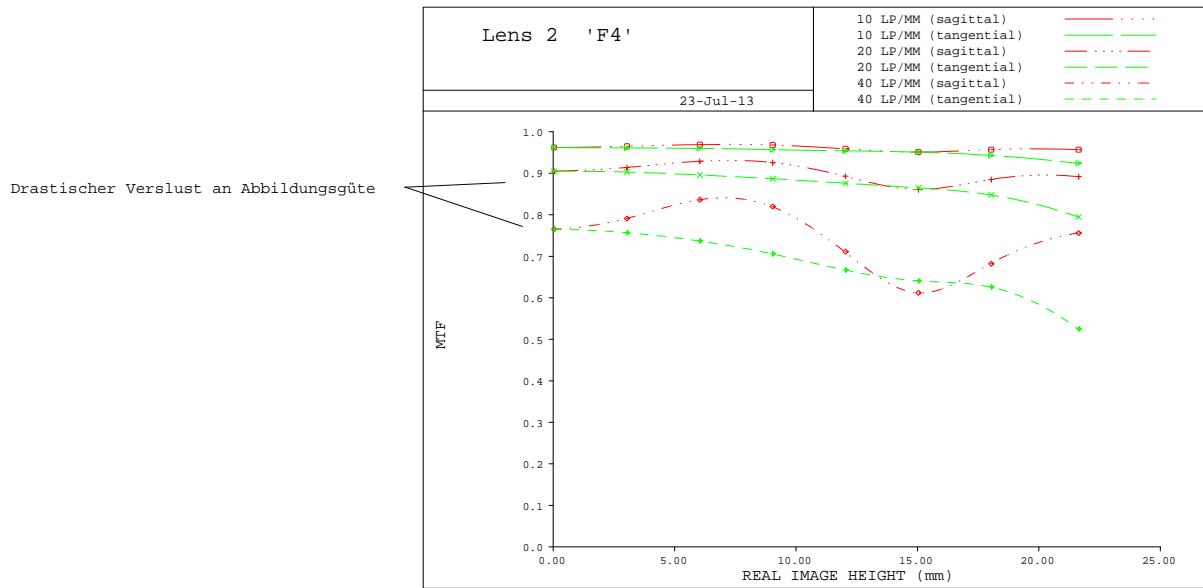

An explanatory picture as an example



Fig. 2: lens with excellent contrast rendition



Fig. 3: lens with low contrast rendition

Technical Reason 2 – Color Fringe Image Quality

For lenses with the highest image quality, freedom from color fringing is an absolute MUST.

The commonest causes for the appearance of color fringes in the picture are longitudinal and lateral chromatic aberrations. However, for the highest demands, it is not enough to remove both these aberrations by choosing the appropriate glass. It is necessary to monitor and remove higher order aberrations such as Gauss errors and the chromatic variation of the position of the image shell.

The following graphic representations show the spherical aberrations and the position of the image shell for various wavelengths. For lens 3, a leaded KZFS glass type was used once again. In lens 4, it was attempted to re-produce the system using a lead-free SNBH glass type. It was not possible to re-attain the high quality of the correction of the Gauss error and the chromatic variation of the position of the image shell.

The reason for this can be found in the characteristics of the dispersion curve of the types of glass, which was mentioned at the outset. Both glass types of the short flint group should be included in the calculations. Nevertheless, the crown glass character (lower P_{gF} value) is more clearly pronounced in the KZFS than the SNBH glass type.

Consequence: While in the graphic representation of system 3 there is hardly any evidence of color fringes, they are impossible to miss in the image of system 4.

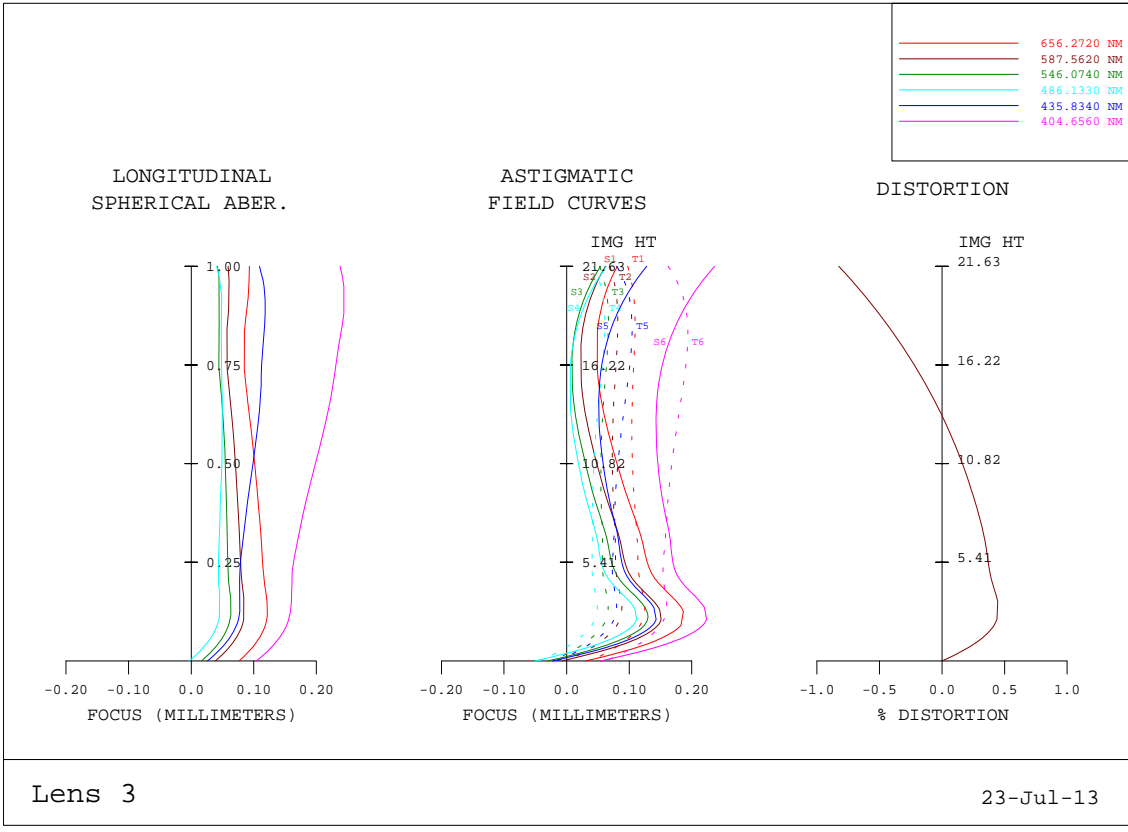

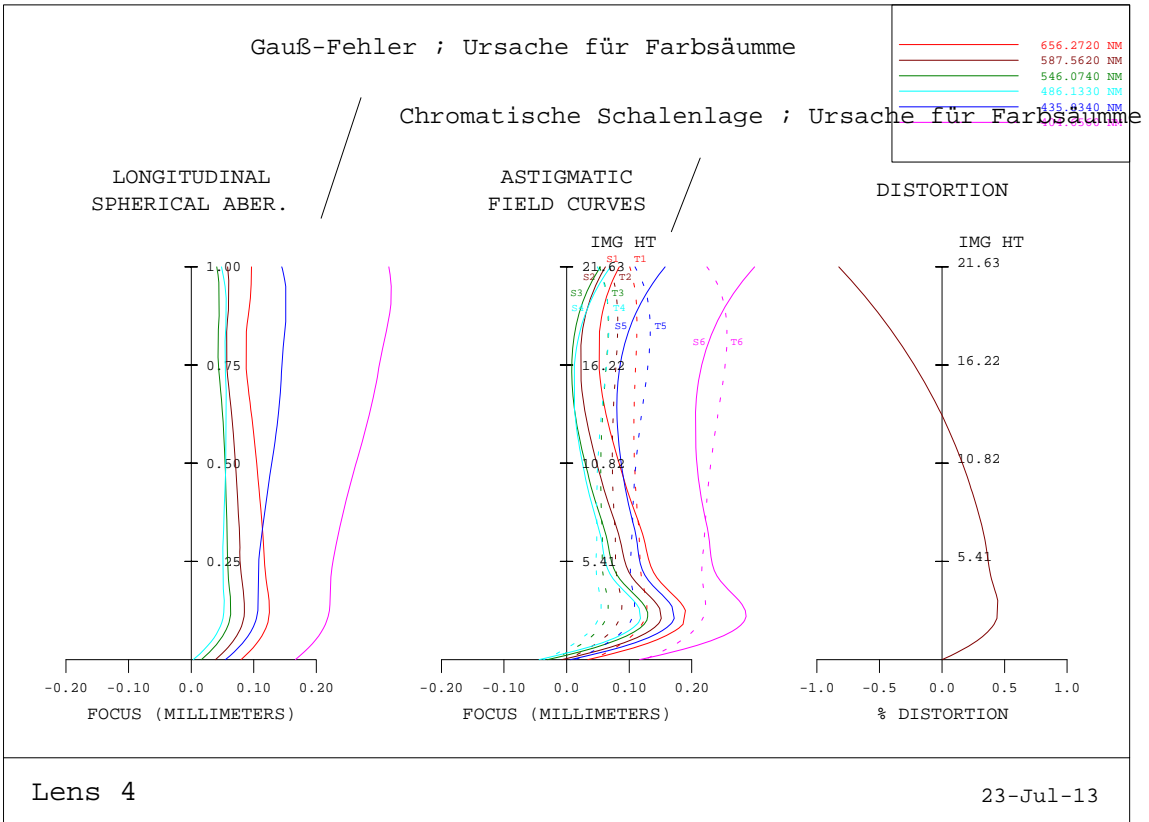

The problem of color fringes – especially on edges with high contrast – is easily recognizable in the following pictures.

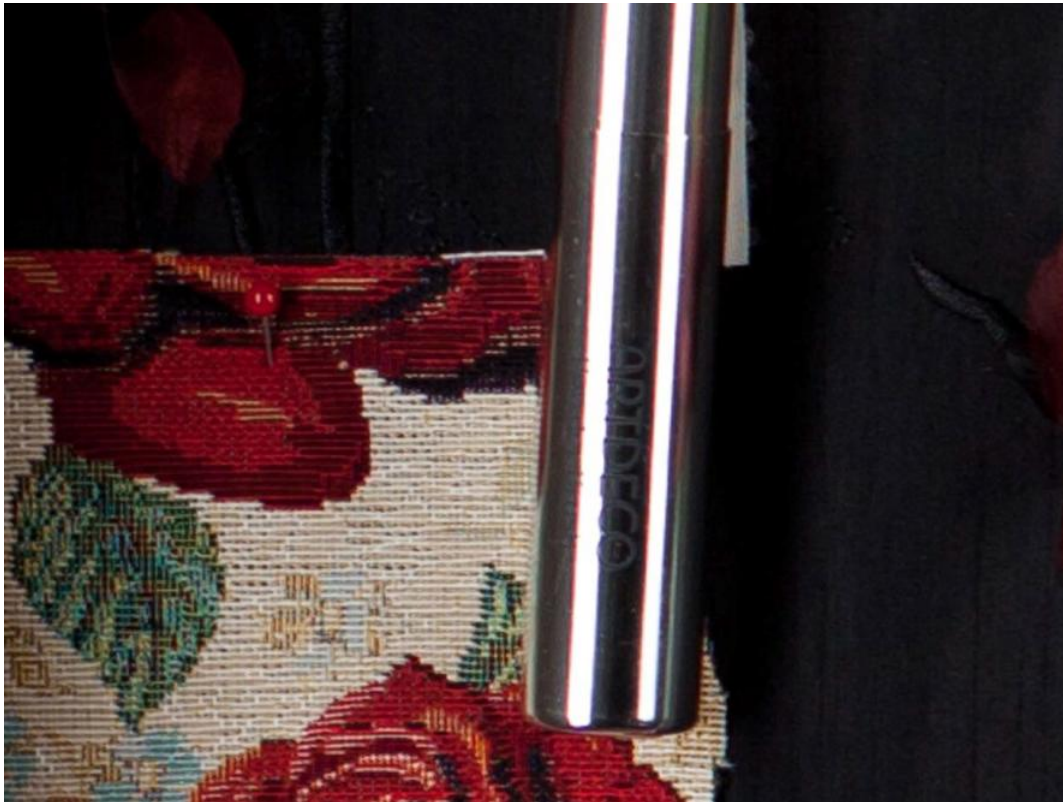

Fig. 4



Fig. 5

Technical Reason 3 – Image Quality

Due to the necessary high demands in relation to the quality of the products, in many cases there will be no more new optical solutions, if lead in types of optical glass is dispensed with.

If there are alternative solutions, then significant additional inputs in terms of resources such as time and material costs will be required. These will carry significant drawbacks in relation to competitors who are not bound to RoHS. The efforts made over many years of development will have been in vain.

The following graphical representations show a comparison between two lenses as to what additional input is required due to dispensing with leaded glass types, if the image quality is to be re-attained.

It must also be mentioned that a larger quantity of optical components inevitably leads to a reduced image quality as a result of a higher level of stray light and reflections.

In the case of a lens with leaded glass types, 12 elements (three cemented components) are necessary. (Image above). In the case of a lens with lead-free glass types, 14 elements (four cemented components) are required to reproduce the image quality. This additional input also

means the increased use of raw materials, energy and equipment, which inevitably leads to an increase in waste products.

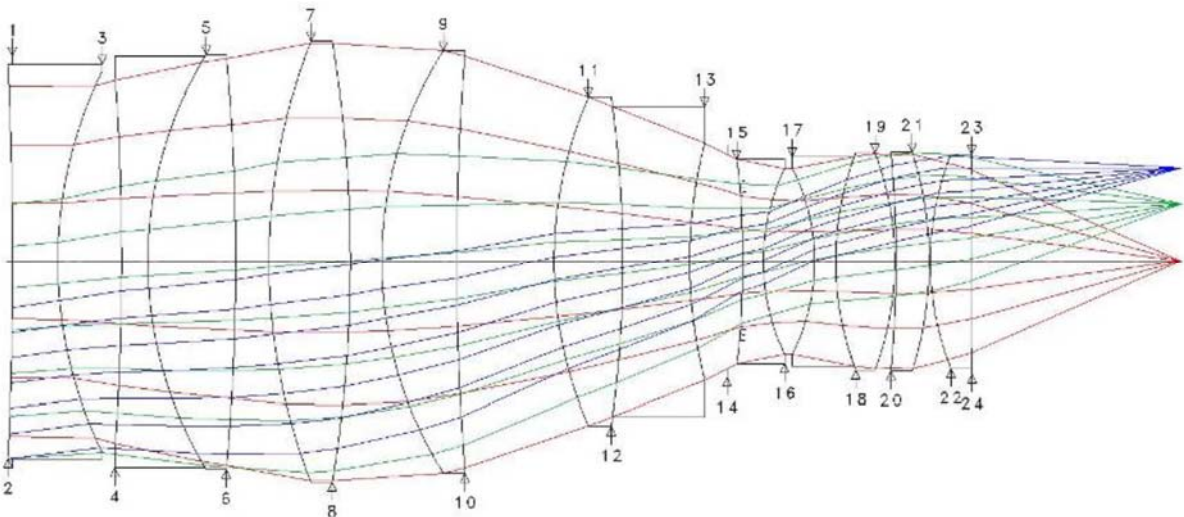

system with leaded glass types

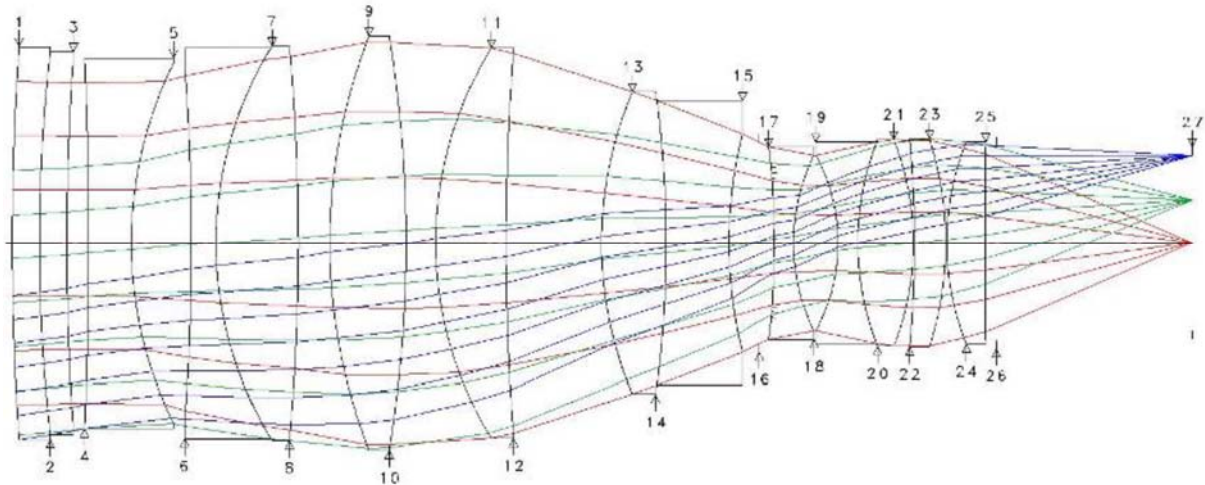

system with lead-free glass types

In addition to these economic aspects however, we must also bear in mind the consequences for the imaging process.

To this end, we firstly observe the relationships on a glass plate which, for simplicity, we take as representative of a single lens element, and assume an absorption loss of 10% in the glass and a reflection loss of 1% on glass-air transitional surfaces (averaged over the spectral range, which is realistic even with multi-coating of the surfaces).

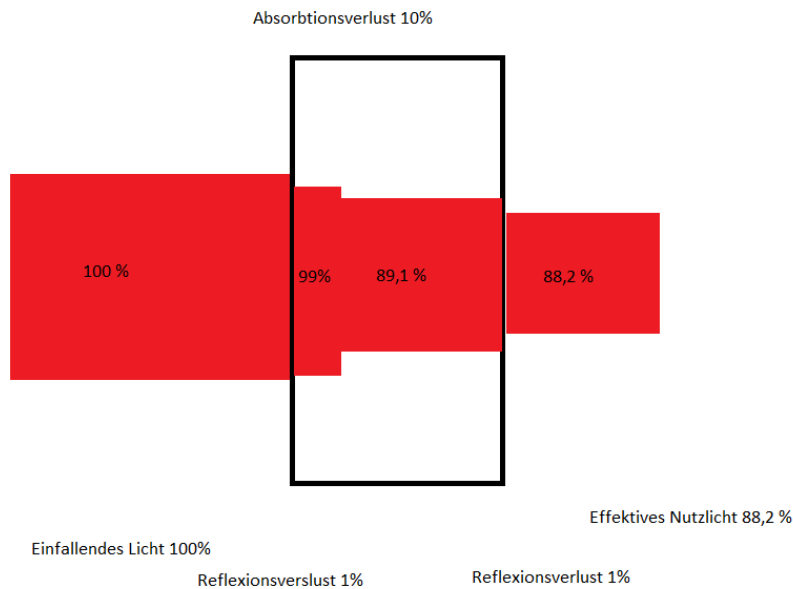

After going through the elements, a loss of useful light of 10% occurs when the reflection losses are omitted, and a loss of 11.8% when reflection losses are taken into consideration.

Assuming we have a system comprising 10 elements, we obtain the following result for effective useful light: $100\% \cdot 0.9^{10} = 35\%$ without taking reflection into consideration, and $100\% \cdot 0.882^{10} = 28\%$ when reflection is taken into account. The difference of about 7% now strays through the system, is largely absorbed in the process, and a small proportion exits harmlessly at the system's front face in the object area, but a small proportion also exits harmfully at the system's end face in the image area and ends up as stray light on the recipient. The more elements the lens contains, the less favorable the relationship between effective useful light and stray light.

See in this regard the following estimation for stray light, whereby we only take into account the proportions of stray light which are created through reflection between the exit and entry areas of consecutive plates.

The remaining useful light following the first plate is reflected on the entry area of the second plate to 1%, of which in turn 1% is reflected on the exit area of the first plate, i.e. the proportion of stray light as a result of the reflection between both these plates amounts to:

$$100\% \cdot 0.882 \cdot 0.01 \cdot 0.01 \cdot 0.882^{N-1} = 100\% \cdot 0.882^N \cdot 0.01^2 = \text{useful light} \cdot 0.01^2$$

Thus, when all proportions of stray light which are created due to reflections of consecutive plates are taken into consideration, the stray light proportion in N plates amounts to:

$$\text{stray light} = \text{useful light} \cdot 0.01^2 \cdot (N-1).$$

In the case of significant contrast differences in the picture, this value which at first seems small may prove very disruptive and can even lead to the loss of image contents. Here is an example:



Fig. 6

Note especially the details of the scissors and the comb in the upper left corner

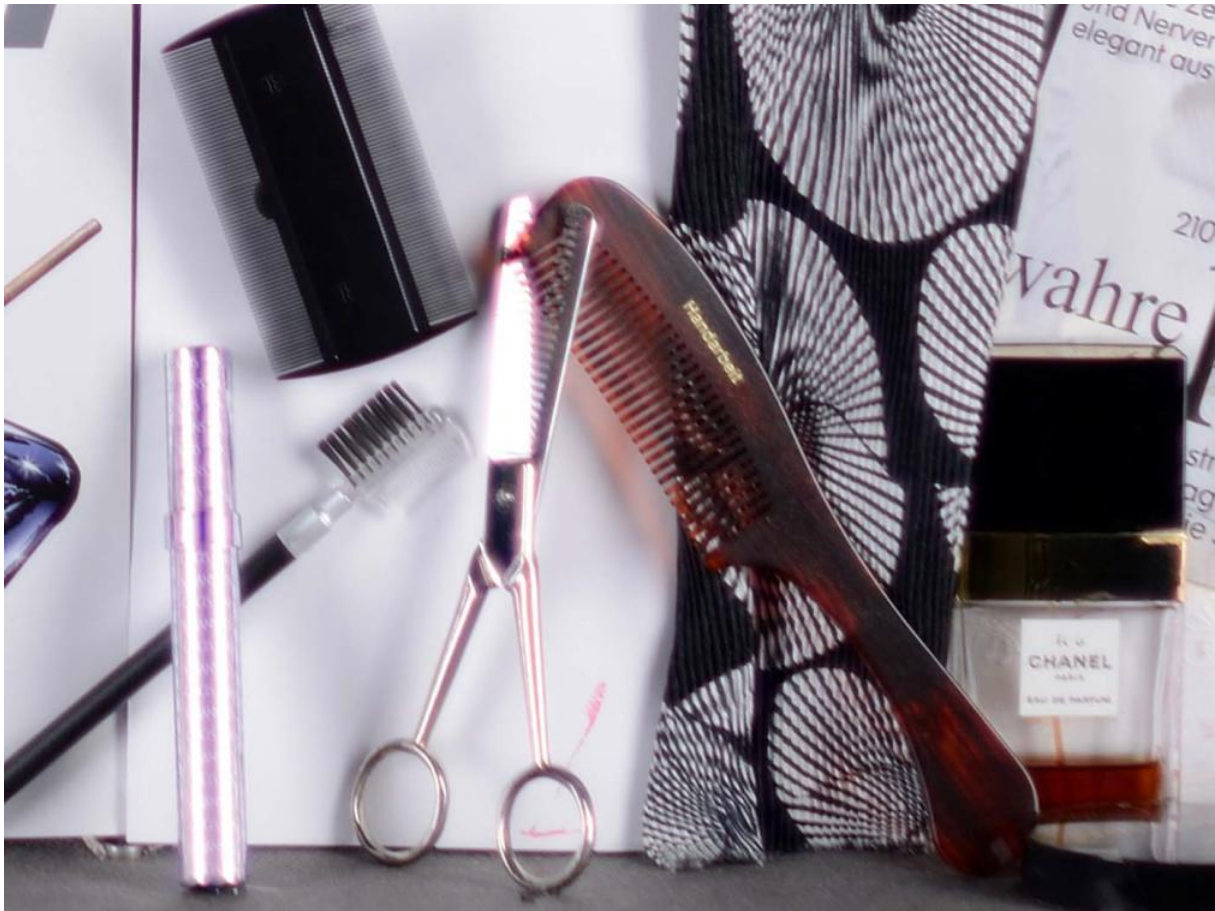

Fig. 7

Due to a poor relationship between useful light and stray light, depending on contrast in the picture, these details are fully or almost fully erased.

Far more unpleasant however, is the generation of reflections, whereby due to the reflective effect of two system surfaces, a concentration of stray light proportions is produced, leading to a very noticeable light intensity. Even when the utmost care is taken in the design of the optical system, these effects absolutely cannot be avoided and, of course, the more lens elements the system contains, the greater the tendency to generate reflections.

Here are a few examples:



Fig. 8



Fig. 9



Fig. 10



Fig. 11

No commentary is required.

Technical Reason 4 – Transmission Problems; Color Location

Unlike leaded glass types, lead-free glass types tend towards a higher absorption of the emitted light – in particular in the blue range of the spectrum. This causes a significant change in the transmission characteristics of the lenses. As a result, the images' color location is noticeably altered. The following table shows a comparison between the absorption loss of a lead-free versus a leaded lens version (Table 1).

The standardization of the color characteristic of the lenses, which is necessary in the area of cine-lenses, can only be attained using lead-free glass types with significant additional input.

Table 1:

Wavelength	656	622	587	566	546	516	486	460	435	420	404
Lens 7 absorption loss	0.985	0.985	0.985	0.985	0.984	0.977	0.963	0.941	0.901	0.828	0.657
Lens 8 absorption loss	0.947	0.954	0.961	0.960	0.956	0.928	0.892	0.854	0.782	0.699	0.464
Difference	0.038	0.031	0.024	0.024	0.028	0.050	0.071	0.087	0.119	0.129	0.193
Loss in %	3.83	3.15	2.47	2.47	2.85	5.08	7.34	9.21	13.23	15.53	29.35

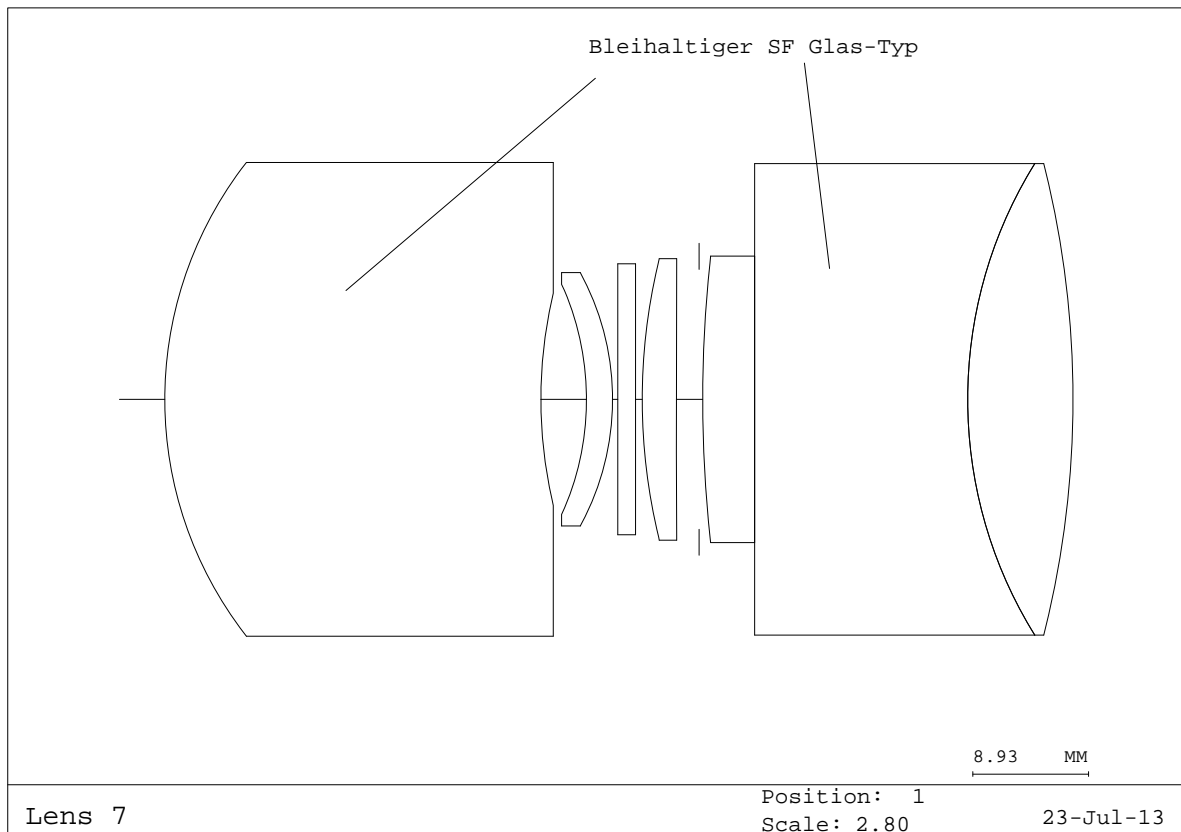

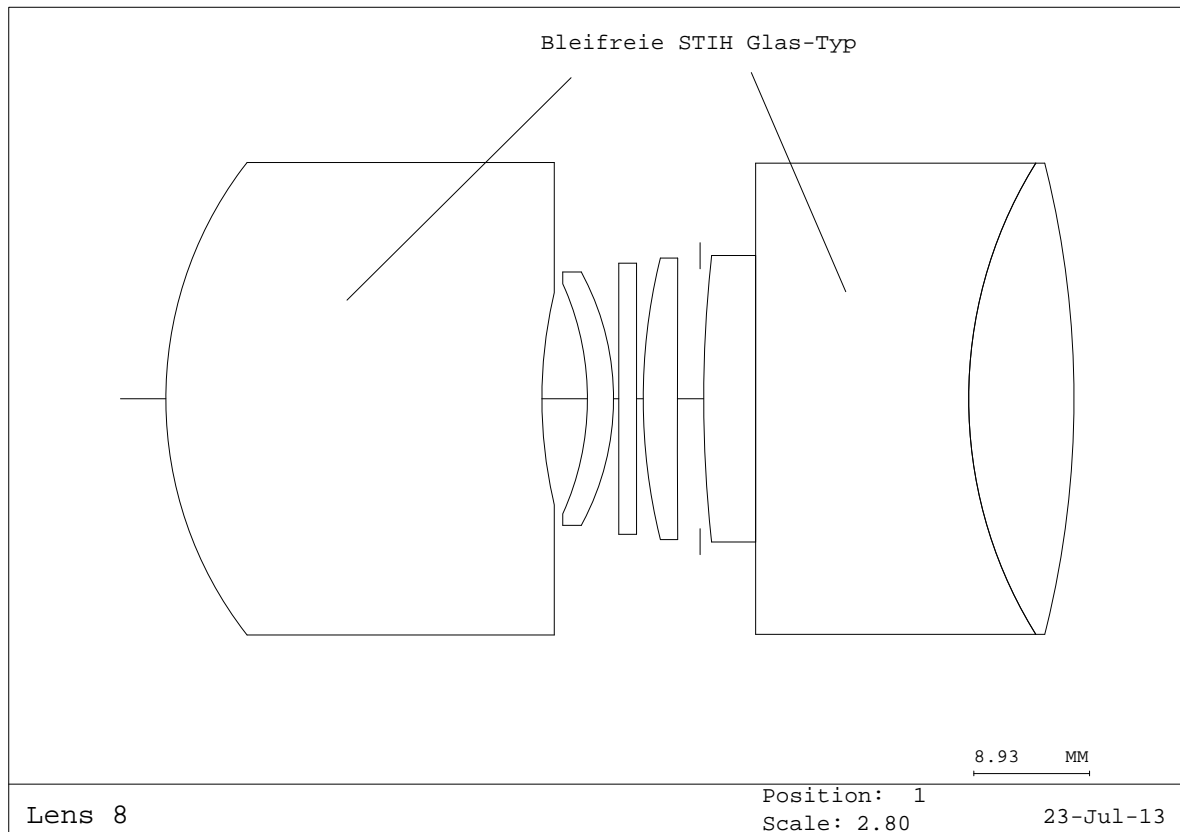

Let us now observe, in a somewhat more general way, the absorption losses in the spectrum's "blue" range (400~440 nm). In this range, the transmission of an individual lens element made of leaded glass can be assumed to be 90% on average, while for lead-free glass approximately 80% may be estimated. If the calculation of the effective useful light from Point 3 is carried out for both these cases, the result for leaded glass is as follows:

effective useful light = 35%

and in the case of lead-free glass:

effective useful light = 11%

This difference leads to a clearly visible displacement of the image's color location to "warmer" colors and thus to a visible displacement of the color location.



Fig. 12: image with color location 0/4/4



Fig. 13: image with color location 0/16/16

The shift of the image's color impression with the color location 0/16/16 to the "warmer" yellow/red color tones due to insufficient blue transmission is obvious.

Technical Reason 5 – Transmission Problems; Achromatization and Petzval Sum

To achieve maximum imaging performance with changeable lenses, a variety of image aberrations must be corrected to the minimum values – ideally at the same time. The chromatic aberrations and the Petzval sum of a lens are two basic factors.

The image points which are assigned to an object-side level perpendicular to the axis form a curved area known as the Petzval shell. At the first approach, it may be seen as a spherical area whose radius is given by the following:

$$1/R_p = -n'_n * \sum_1^n (-(1/r_v) * D(1/n_v))$$

r_v represents the radii of the system surfaces, $D(1/n) = 1/n_v - 1/n'_v$ (Sizes in accordance with a surface are usually marked by a vertical bar), n_v and n'_v the refractive indices before and after a system surface, the sum covers all surfaces of the system.

The sum can alternatively be expressed as:

$$1/R_p = -(n'_k/n_1) * \sum_1^k (F_k/n_k)$$

whereby the sum is to be made up of the lens elements contained in the system and F_j denotes the refractive power of lens element j .

For outstanding image quality across the entire image field, the image field must be as even as possible, i.e. $1/R_p \rightarrow 0$.

The most effective means of fulfilling this condition is the appropriate generation of the system structure (configuration of positive and negative refractive powers in the system). However, this leads to voluminous constructions which prove unwieldy when used in general photography.

A comparison of the Petzval sum with the achromatism condition

$$\sum_{i=1}^{i=n} (g(i) * F(i)) / (v(i) * F) = 0$$

shows a solution however; even if it is clearly less effective. Since a positive total refractive power must be reached (it should represent an imaging system, after all), it must be ensured that the positive refractive powers outweigh. In order to minimize the Petzval sum, glass types with the highest possible refractive index are selected for lens elements with positive refractive power and glass types with a low refractive index are chosen for lens elements with negative refractive power. In order to handle the color correction at the same time, glass types with a high Abbe number are selected for lens elements with positive refractive power, and glass types with a low Abbe number are chosen for lens elements with negative refractive power.

To eliminate chromatic aberrations, it is essential to use achromats. Two different achromat structures are possible:

- Old achromat: the positive lens element is assigned a significantly higher Abbe number v_d than the negative lens element, while the negative lens element has to be allocated a higher refractive index n_d .
- New achromat: the positive lens element is assigned both the higher Abbe number and the higher refractive index than the negative lens element.

In both cases, the difference between the Abbe numbers should be as large as possible.

To correct the Petzval sum – a fundamental factor of an optical system – the new achromat is the preferred version. For the most compact design possible – in particular with complex lens designs – ease of use is a key quality feature. However, the refractive index of the positive lens element should be as high as possible.

As a result, the negative lens element must be selected from the area of the SF glass type.

However, a comparison of the transmission properties of the leaded SF glass types with the corresponding lead-free SF glass types shows significant differences in transmission right in the blue spectral range. These differences must be considered unacceptable for an adequate color location of the lens.

Table 2: Absorption of a 5 mm thick glass plate on 435 nm and 404 nm wavelengths

leaded	435	404	435	404	lead-free
Sf2	0.9960	0.9920	0.9893	0.9893	S-Tim22
Sf15	0.9930	0.9681	0.9797	0.9289	S-Tim35
Sf10	0.9920	0.9541	0.9779	0.9152	S-Tih10
SF4	0.9930	0.9810	0.9773	0.9192	S-Tih4
SF6	0.9910	0.9660	0.9733	0.9180	S-Tih6
Sf57	0.9860	0.9391	0.9193	0.4644	S-Nph3
SF57	0.9860	0.9391	0.9565	0.8817	S-Tih53
SF59	0.8898	0.6704	0.9040	0.5714	S-Nph2
SF58	0.9299	0.7803	0.9040	0.5714	S-nph2

In order to avoid this dilemma of the appropriate color location, glass types with more favorable transmission should be chosen for the lens elements with negative refractive power. However, these generally have higher Abbe numbers. Therefore, in order to fulfill the achromatism condition, glass types with higher Abbe numbers should also be chosen for lens elements with positive refractive power. Nevertheless, in this type of glass, high refractive indices – necessary for the correction of the Petzval sum – are not available.

Summary

- In order to meet the highest demands in relation to optical imaging performance, leaded glass types are extremely important on the basis of their specific characteristics. Alternative approaches require additional input in terms of lens elements which leads to a marked competitive disadvantage in relation to competitors who are not bound to RoHS.
- If leaded glass types are dispensed with, the reparability of a variety of optics may no longer be satisfactorily guaranteed, as possible lead-free replacement glass types show major differences in certain of their essential characteristics. For our customers, this means a long-term devaluation in their investments in quality optics from Carl Zeiss, which in turn leads to damage to the Carl Zeiss brand.